

The
BELMONT



More Than A Window.™

Appealing Views

Ideal Complement —

New Windows: Improving Your Lifestyle

The *Belmont* series from Alliance Window Systems[®] offers the features and benefits usually found only on the most expensive windows ... at an exceptional value. Created with meticulous engineering and efficient manufacturing technology, the *Belmont* series makes replacing those old drafty windows an easy choice.

Remodeling your home? Your options are open with the *Belmont* series. Select from double- or single-hung, twin or single vent slider, picture windows or casements. No matter what your home's styling and décor, Alliance Window Systems' *Belmont* series has a style that will harmonize beautifully.

The
BELMONT

With *Belmont*, you receive beauty and brains. Your windows will be thermally efficient, and easy to clean and operate. Designed with a balance system that never needs adjustment, our windows are maintenance free. And, they are backed by one of the industry's strongest warranties – our exclusive Assurance Plus[®] warranty.



Double-Hung Features

Non-corrosive hardware includes a lifetime of trouble-free performance, no matter what the environment.

- (1) Cam Lock action draws sashes closer together for positive lock
- (2) Interlocking Meeting Rail: Integral interlock provides additional security

Anatomy of Efficiency

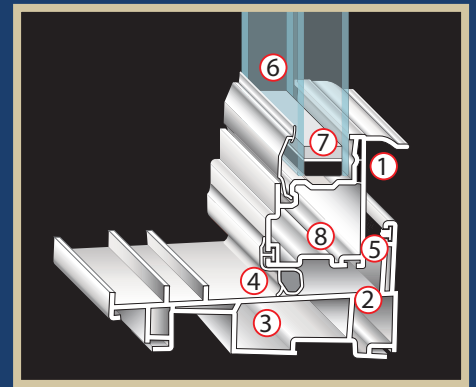

Energy efficient Belmont windows provide an effective barrier to any weather condition.

- (1) Dual hollows at lift rail add strength and insulation
- (2) Heavy walled PVC framing acts as a natural insulator
- (3) Dead air spaces within the frame and sash profiles further resist energy flow
- (4) Closed cell compression seal at sloped sill resists air and water penetration
- (5) Fin seal weather stripping at sill reduces air infiltration even more
- (6) 3/4" Insulating glass provides optimal energy efficiency
- (7) "Warm edge" low conductance spacer resists energy flow through the edge of glass
- (8) Water management grooves channel moisture away from insulated glass sealant

Double-Hung Features

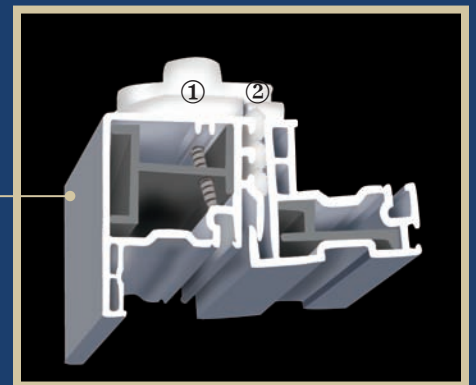

for your home.



Style That Fits –

Slider Features

- Two sets of double-wheeled brass rollers transfer weight of glass directly to frame reducing stress on sash members
- Rollers glide on integral track system allowing for effortless fingertip operation
- Both sashes lift out for easy cleaning
- Independent weep chambers on frame assure effective water run-off

The
BELMONT

You'll love our windows for all of the things they bring into your home – and for all the things they keep out.

Casement Features

- Sash opens completely, so windows can be cleaned easily from inside your home
- All components are corrosion resistant, providing years of trouble-free performance
- Multi-Point Locking System locks sash at multiple points – for utmost security
- Three layers of weather stripping assure effective barrier to air and water penetration
- Top rated hardware system allows even the largest casements to be effortlessly and smoothly operated



Casement Profile



- (1) Multi-point lock
- (2) Heavy-wall reinforced construction: Allows for slim-line look while insuring maximum strength and durability
- (3) Low profile curved lock: Lies flat, out of the way of window treatments
- (4) Low torque operator: Crank requires 33% less operating force; fold-down handle available



The Belmont has a unique profile sash and narrow frame to allow maximum exposed glass area.

into your home.



Single-Hung



Single Slider



Belmont Single-Hung and Single Slider

- High-quality
- Energy efficient
- Economically priced

Livingston –
AWA's "green"
spokesperson



Committed to Being Green

The American Window Alliance sees building green as the future, not a fad. We are developing earth-conscious solutions in our products with proven environmentally-friendly materials and practices. With our commitment to environmental leadership and innovation through experience, technology and superior craftsmanship, the AWA is proud to help in the building of a greener world – one window at a time.

InnovativE[®] ENERGY MANAGEMENT SYSTEM

Did You Know...

Each 0.01 U-value improvement in windows can save up to 400 lbs. of CO₂ per home in a year. The AWA's InnovativE[®] glass package can improve total U-value by up to 0.03!

Windows that last 20 years can save up to 16 tons of CO₂ production in an average home. Additionally, all of our window components are recyclable.

It takes three full-grown trees one year to absorb one ton of CO₂ (a typical home). The AWA's InnovativE[®] glass package saves 1,200 lb. to 1,600 lb. of CO₂ produced in an average home.





The craft of window design is the union of experience with technology.

Spacer Performance

Duralite® spacers are the best spacers in comparison testing with other commonly used insulated glass systems. Duralite® spacers yield a lower window U-value – up to 0.03 over other less efficient systems. And that means more comfort and energy savings for you.

Condensation Resistance: No spacer system can eliminate condensation, but Duralite® reduces conductivity by 50% over other warm edge spacers. Reducing conductivity also reduces condensation.

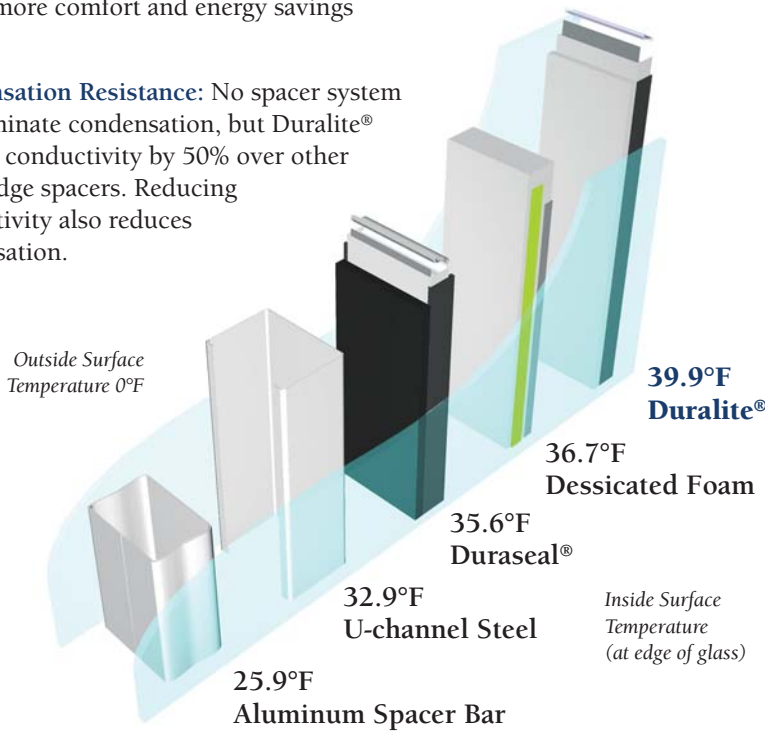

Easy Operation and Cleaning



Window cleaning is simplified with tilt-in upper and lower sashes.

Window Features	Poor Solution	Average Solution	The Belmont Solution
Interlocking Sash	No weather stripping or interlock at meeting rail	Weather stripping at meeting rail, no interlock	Weather stripped interlocking sashes
Glass Package	Single glazed, possibly with storm windows	1/2" Clear insulating glass, inefficient metal spacer	3/4" InnovativE LowE warm edge non-conductive spacer
Locks/Keepers	Single "sweep arm," lock keeper is part of frame	Pop-rieveted "sweep arm" lock, keeper attached to rail	Screwed-in "Cam-Action" lock, keeper screwed to rail
Frame/Sash Material	Screwed together wood or aluminum	Screwed together vinyl or clad wood	Fusion-welded vinyl for maximum strength and integrity
Vent Latch	None	Single "pry out"	Double "toggle out" (has passed AAMA Forced Entry Resistance Test)
Warranty	None or limited	20 years, for parts only	Lifetime, with initial coverage for labor
Glass Spacer	None	Heat conductive metal	Duralite® composite metal

Accessories

Select from many popular options to further enhance the appearance of your windows. Choices include Colonial or brass grids that fit securely within the insulating glass space, special designer glass and obscure glass.

Accessory offerings vary among Alliance members based on geographical demands. Please check with your regional Alliance manufacturer for details.

Standard Extruded Colors

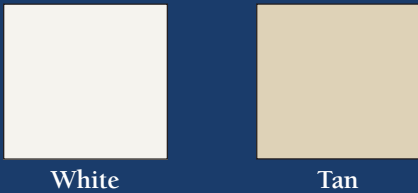

Additional colors and exterior finishes are offered by many Alliance members. Please contact your local Alliance manufacturer for color availability.





Lifetime Warranty

Alliance is not just our name. It also accurately describes our approach to doing business, and it's why we can provide such an exceptional warranty on every window we offer for your consideration. A proud, independent regional fabricator of excellent experience and reputation meticulously crafts each of our windows. By linking these carefully selected and exceptional fabricators into a national network, or alliance, we are able to be so confident of the quality that is designed and built into our windows; we can back our entire product line with an unsurpassed warranty.

Of course, other window companies may also say they offer a warranty, but we urge you to carefully read their fine print. They may, for example, guarantee the vinyl extrusion, but what about all the moving parts or the insulated glass? The Alliance Assurance Plus® Limited Lifetime Warranty covers it all – for life! Even more remarkable, if a factory defect needs repair within the first five years, we will even provide the labor required.

Many windows leave you wide open to unpleasant surprises. Select a window from Alliance Window Systems® and you'll know it's backed by a warranty second to none.



More Than A Window.

www.alliancewindows.com



Look for the
ENERGY STAR
label on qualified
products.